

DAVID D. BROWN
CHAIRMAN

DAVID F. BRANDT
VICE-CHAIRMAN

RICHARD A. LAHAIE
COMMISSIONER

KENNETH PAQUET
COMMISSIONER

HENRY GINOP
COMMISSIONER

Cheboygan County Road Commission

5302 South Straits Highway
Indian River, Michigan 49749

Phone: (231) 238-7775

Fax: (231) 238-0830

877-257-2272

R. BRENT SHANK
ENGINEER/MANAGING DIRECTOR

DANA S. STEMPKY
CLERK

BID NOTICE - 2019

Sealed Bids will be received at the office of the Cheboygan County Road Commission, located at 5302 South Straits Hwy, Indian River, Michigan, 49749, until **9:00 a.m. on Tuesday, February 19, 2019**, at which time and place they will be publicly opened and read aloud for furnishing the annual requirements of the following items:

- | | | | |
|-------|--------------------|-------|--------------------------|
| 19-01 | Aggregate Material | 19-02 | Bituminous Emulsion |
| 19-03 | Cold Patch | 19-04 | Hot Mix Asphalt Patching |
| 19-05 | Culvert Materials | 19-06 | Dust Control/Brine |
| 19-07 | Grader Blades | 19-08 | Hot Mix Asphalt |
| 19-11 | Pavement Markings | 19-12 | Plow Shoe & Wing Shoe |
| 19-13 | Road Signs | 19-14 | Aggregate Processing |
| 19-15 | Tires | | |

Please contact our office by calling 231-238-7775, faxing 231-238-0830 or by sending an e-mail (PREFERRED METHOD) to engtech@chcrc.com to obtain bidding package and specifications. All bids must be submitted on CCRC Bid Sheets in a sealed envelope (one item per envelope) clearly identifying the bidder and bid item. All Bids Shall be valid for a period of one year from the date of award.

Bids will be awarded at the regular Road Commission Board meeting on February 21, 2019. The Cheboygan County Road Commission reserves the right to accept or reject any and all bids, in whole or in part; to waive irregularities or informalities; and to award bids, in whole or in part, as deemed to be in the best interest of the Cheboygan County Road Commission.

MDOT specifications must be met and material certification provided.

BOARD OF COUNTY ROAD COMMISSIONERS
COUNTY OF CHEBOYGAN, MICHIGAN

DAVID D. BROWN
CHAIRMAN

DAVID F. BRANDT
VICE-CHAIRMAN

RICHARD A. LAHAIE
COMMISSIONER

KENNETH PAQUET
COMMISSIONER

HENRY GINOP
COMMISSIONER

Cheboygan County Road Commission

5302 South Straits Highway
Indian River, Michigan 49749

Phone: (231) 238-7775

Fax: (231) 238-0830

877-257-2272

R. BRENT SHANK
ENGINEER/MANAGING DIRECTOR

DANA S. STEMPKY
CLERK

GRADER BLADES BID

CCRC Bid No. 19-07

The Cheboygan County Road Commission will accept sealed bids for supplies pertaining to Grader Blades needs. This Bid will be for supplying our annual Grader Blades needs for the 2019/2020.

Bids shall be submitted on the enclosed CCRC Grader Blades Bid Sheet in a sealed envelope clearly indentifying the bidder and marked "Grader Blades".

Price to be held for a period of 1 year from acceptance.

CCRC is tax exempt from all State and Federal Taxes.

Bids are due at **9:00 a.m. on Tuesday, February 19, 2019**, at which time, the bid will be publicly opened and read aloud. Bid results will not be available until they have been tabulated and presented with recommendations and approved by the Road Commission Board at their next regular meeting on February 21, 2019.

Cheboygan County Road Commission reserves the right to accept or reject any and all bids, in whole or in part; to waive irregularities or informalities; and to award bids, in whole or in part, as deemed to be in the best interest of the Cheboygan County Road Commission.

Travis Horrocks, P.S.
Engineer Technician

engtech@chcrc.com

(231)238-7775

Enclosures

Cheboygan County Road Commission
2019 Grader Blades
 19-07 Bid Sheet

(To be completed by bidder in ink or typewritten)

Company Name: _____

Address: _____

City: _____ State: _____ Zip: _____

Phone: _____ Fax: _____

Contact Person w/Title: _____ E-Mail: _____

Description:	Price per lbs	Weight per Foot	Price per Foot
--------------	---------------	-----------------	----------------

Front Plow Blades

High Carbon Steel Cutting Edges (Pg 3)

5/8" x 8" - 6' or 7' lengths	_____	_____	_____
------------------------------	-------	-------	-------

Wing Plow Blades (9' Monroe Model 9SFWMB, 9DFWMB, 316, STR) (7' Monroe Model 7JRWMB)

High Carbon Steel Cutting Edges (Pg 4)

5/8" x 8" Curved 9' lengths	_____	_____	_____
-----------------------------	-------	-------	-------

5/8" x 8" Curved 7' lengths	_____	_____	_____
-----------------------------	-------	-------	-------

Underbody Blades

Hardened Blades (extra Edge or Equal)(Pg 5)

5/8" - 7/8" x 8" - 6' or 7' length	_____	_____	_____
------------------------------------	-------	-------	-------

Sectional Tungsten Carbide Blades(Pg 6)

5/8" x 6" Curved 4' lengths	_____	_____	_____
-----------------------------	-------	-------	-------

3/4" x 6" Flat 4' lengths	_____	_____	_____
---------------------------	-------	-------	-------

7/8" x 5" Flat 4' lengths	_____	_____	_____
---------------------------	-------	-------	-------

Serrated Ice Blades(Pg 7)

5/8" x 8" 6' lengths	_____	_____	_____
----------------------	-------	-------	-------

3-3/8" space, 1-5/8" tooth**	_____	_____	_____
------------------------------	-------	-------	-------

1-3/16" space, 2-1/8" tooth**	_____	_____	_____
-------------------------------	-------	-------	-------

** Tooth & Spacing size approximate

Carbide Bit Moldboard Blades(Pg 8)

Motor Grader Moldboard Blade (1-3/4" tool spacing)	_____	_____	_____
--	-------	-------	-------

Truck Underbody Moldboard Blade (1-1/2" tool spacing)	_____	_____	_____
---	-------	-------	-------

Carbide Bit Tools(Pg 9)

Motor Grader Blades Per Qty Specified _____			_____
---	--	--	-------

Truck Underbody Blades Per Qty Specified _____			_____
--	--	--	-------

Allowable Discounts, Payment Terms and Shipping terms:

Authorized Signature	Date	Printed Name
----------------------	------	--------------

SPECIFICATIONS FOR
HIGH CARBON STEEL CUTTING EDGES
FOR
FRONT PLOWS

Blade: 5/8" x 8" material to be steel AISI C-1080 quality within the chemistry specifications.

Hardness: To be Rockwell Hardness C – Scale from 25.4 to 34.7 and/or have a Brinell Hardness (HBW 10/3000) from 255 to 325.

Blade Length:

Length of blades to be stated at time of order, depending on make & model of plow blades needed.

Blade Punching:

All blades shall be furnished with appropriate bolt holes punched or drilled as required by society of automotive engineer's specification no. J740. Hole spacing dimensional tolerances shall be $\pm 1/16$ " non-accumulative, hole size, spacing & length will be stated at time of the order.

Camber Tolerance:

The actual camber shall be measured at the midpoint of the edge from a straight line extending from one end of the edge to the other end. Maximum camber shall not exceed 1/8" for all lengths 0 feet through 6 feet, 3/16 for all lengths 6 feet through 10 feet, or 1/4" for all lengths over 10 feet.

Specific Requirements:

Each blade section shall be identified with manufacturers mark, stamped or stenciled on each end of the sections. Must have certificate of quality & material analysis sheet and all MSDS sheets needed.

Manufacturer _____ Place of Origin _____

Material Meets Specifications: YES _____ NO _____

Exceptions:

9' Curved Wing Blade wt. => 145 lbs = 45 kg

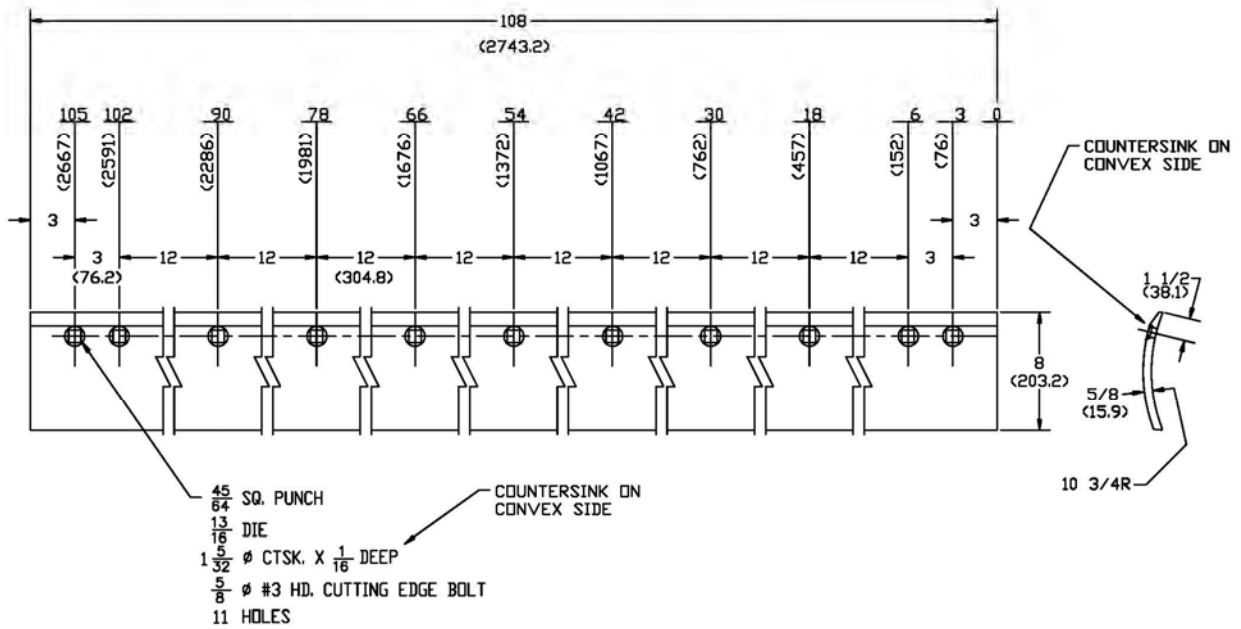

7' Curved Wing Blade wt. => 112 lbs = 51 kg

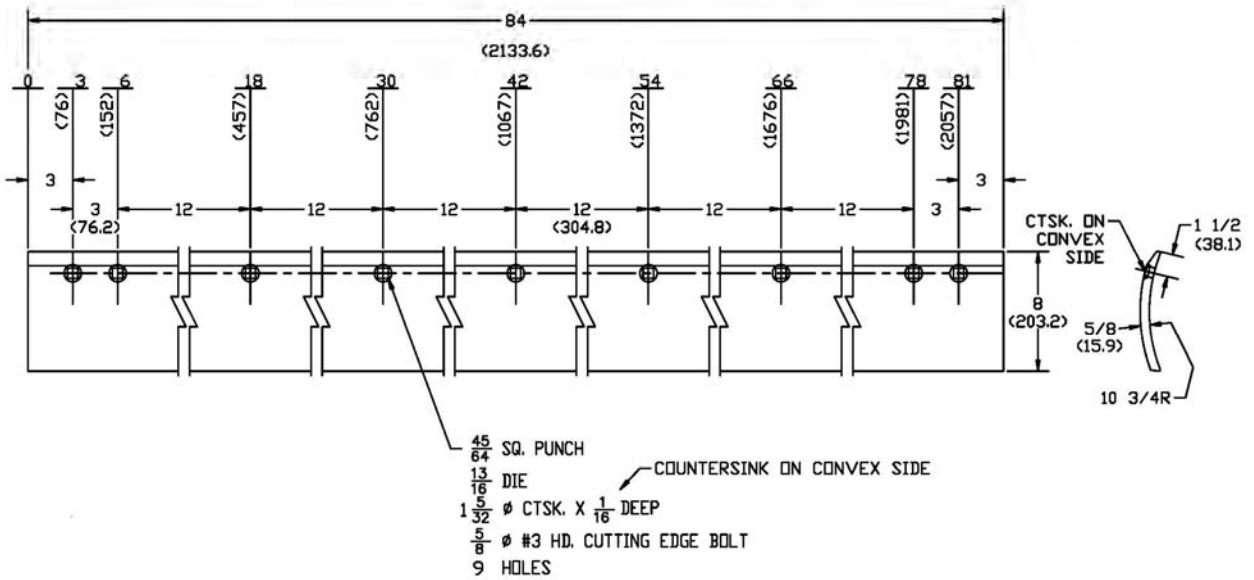

SPECIFICATIONS FOR
EXTRA EDGE OR EQUAL BLADES

BLADE: Blade shall be 5/8” thick on the moldboard edge and 7/8” thick on the wearing edge. Material to be steel A.I.S.I 1074 quality within the chemistry specification – Unified Number G10740.

HARDNESS: The 7/8” wearing edge shall be selectively hardened front and back with a primary and secondary hardness. The primary hardened area to have a Rockwell C hardness of 62 (+/-5) for a depth of 1/8” (+/- 1/32”) at the high point of the hardness pattern. Secondary hardness to have a Rockwell hardness of 45 to 56 with a minimum depth of 1/32” at the high point of the hardness pattern.

PATTERN POSITION: The pattern shall start 5/8” (+/- 1/8”) above the bottom edge of the blade and be a minimum of 3 1/2” in width over the length of the blade with the upper part of the pattern terminating below the position of the bottom edge of a standard moldboard.

BLADE LENGTH: 5/8” – 7/8” x 8” x 72” and 5/8”- 7/8” x 8” x 84” shall not be exceeded and must not be shorter the 1/8” specified in order to fit total moldboard length in various blade combinations. Ends shall be square and cleanly cut.

BLADE PUNCHING: All blades to be furnished with appropriate bolt holes punched or drilled as required per Society of Automotive Engineers Specification No. J740. Hole spacing dimensional tolerances shall be +/- 1/16” non -accumulative. Hole size & spacing to be specified at time of order.

BLADE MARKING: Each blade shall have a legible identifying mark indicating it is a special flame hardened type blade.

CAMBER TOLERANCE: The actual camber (edge straightness) shall be measured at the midpoint of the edge from a straight line extending from one end of the edge to the other. Maximum camber shall not exceed 1/8” for all lengths 0 feet through 6 feet, 3/16” for all lengths 6 feet through 10 feet, and 1/4” for all lengths over 10 feet.

SPECIFIC REQUIREMENTS:

Each blade section shall be identified with manufacturers mark, stamped or stenciled on each end of the sections. Must have certificate of quality & material analysis sheet and all MSDS sheets needed.

Manufacturer _____ Place of Origin _____

Material Meets Specifications: YES _____ NO _____

Exceptions: _____

SPECIFICATIONS FOR
SECTIONAL TUNGSTEN CARBIDE BLADES
12 FOOT UNDERBODY BLADE

BLADE: The blade shall be curved single bevel, hot-rolled finished steel of a chemistry and or grade to match SAE 1020-1040. The groove for the carbide inserts shall be milled in the center of the blade edge.

Carbide blade shall be 3/4" x 6" x 48", curved single bevel, standard MDOT hole punch for 5/8" bolts.

CARBIDE INSERTS:

Carbide: The inserts shall be high shock WC grade of Tungsten Carbide with:

- 10 –12% cobalt content.
- Density 14.1 (min) to 14.6 (max) grams
- Hardness: 87.5 (min) to 89.0 (max) Rockwell "A" scale.
- Transverse Rupture Strength: 350,000 to 400,000 PSI

Dimensions: The inserts shall have the following dimensions:

- a. Height: 0.635" ⁺₋ 0.010" (long side)
- b. Width: 0.365" ⁺₋ 0.005"
- c. Length: 1" Nominal
- d. Bottom Angle: 25 deg. w/ a nose radius of 1/16" minimum

Brazing:

- The brazing material shall be high strength alloy type.
- The braze shear strength to be 30,000 PSI.
- The tungsten carbide inserts shall be positioned in the milled groove at 0.010 inches between the inserts along the entire length of each cutting-edge section.
- The inserts shall be brazed on all sides consistent with sound brazing practices, and no evidence of voids or use of shims.
- Each blade section shall contain one insert of 1" nominal length per each inch of blade section length.

Embedding:

- The crushed carbide shall be the "Blocky" type, which penetrates and compacts in the molten matrix.
- The crushed carbide shall be shall be applied in a hot wire (tig) process to puddle depth of 3/16 of an inch in the parent metal.

SPECIFIC REQUIREMENTS:

Each blade section shall be identified with manufacturers mark, stamped or stenciled on each end of the sections. Must have certificate of quality & material analysis sheet and all MSDS sheets needed.

Manufacturer _____ Place of Origin _____

Material Meets Specifications: YES _____ NO _____

Exceptions: _____

SPECIFICATIONS FOR
ICE/SERRATED BLADES

- BLADE:** 5/8 x 8" x 6' or 7' Curved Double Bevel, Serrated & Thru-Hardened.
- STEEL:** Material to be steel AISI 15B30 quality
- HARDNESS:** Each blade shall be through hardened. The hardness to have a Rockwell C hardness 43 to 50. (Brinell hardness rating: 400-512 BHN)
- HOLE PUNCH:** All blades shall be furnished with appropriate bolt holes counter-sunk as required to a diameter 1/16" larger than the normal diameter of the bolt.

BLADE

- MARKING:** Each blade shall have a legible identifying mark indicating a through hardened/max temp. type blade.

Blades must meet all MDOT specifications along with the specifications listed above.

SPECIFIC REQUIREMENTS:

Each blade section shall be identified with manufacturers mark, stamped or stenciled on each end of the sections. Must have certificate of quality & material analysis sheet and all MSDS sheets needed.

Manufacturer _____ Place of Origin _____

Material Meets Specifications: YES _____ NO _____

Exceptions: _____

SPECIFICATIONS FOR
CARBIDE BIT GRADER BLADES

Blade Adapter

- Boards are heat-treated to RC of 35-40.
- Design shall be smooth face.
- Continuous smooth bar tool engagement face for back blading.
- Blade shall be heat treated one piece design.
- Tool hole spacing:
 - Truck Underbody Blades shall be 1.5” on center.
 - Motor Grader Blades shall be 1.75” on center.
- Tool hole shall be double chamfered.
- Bolt holes shall be either $1\frac{3}{16}$ ” for $\frac{3}{4}$ ” bolts or $1\frac{1}{16}$ ” for $\frac{5}{8}$ ” bolts and shall be counter sunk, 6” on center. Hole size to be determined at time of order.
- Tool angle shall be 30 degrees from adapter face.
- Board shall be $\frac{3}{4}$ ” thick.
- Blades shall be 3’ or 4’ long sections (determined at time of order).

Tools:

SEE ATTACHED DRAWING “TOOLS”

Warranty:

- Blade adapter shall be warranted against breakage for life under normal operating conditions.

Specific Requirements:

Must have certificate of quality & material analysis sheet and all MSDS sheets needed.

Manufacturer _____ Place of Origin _____

Material Meets Specifications: YES _____ NO _____

Exceptions: _____

TOOLS

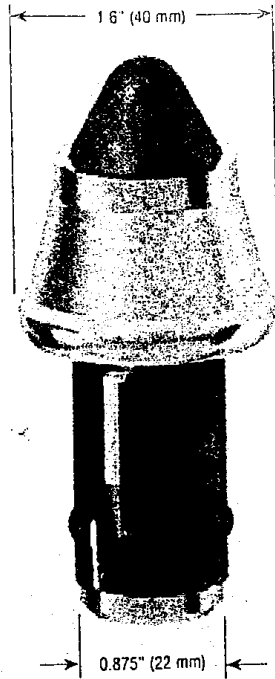

K9LA-2244-7062

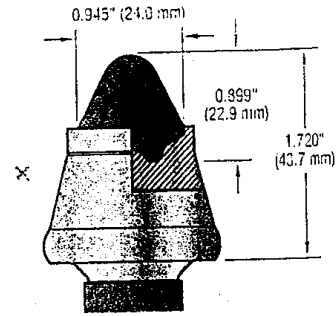

Grader

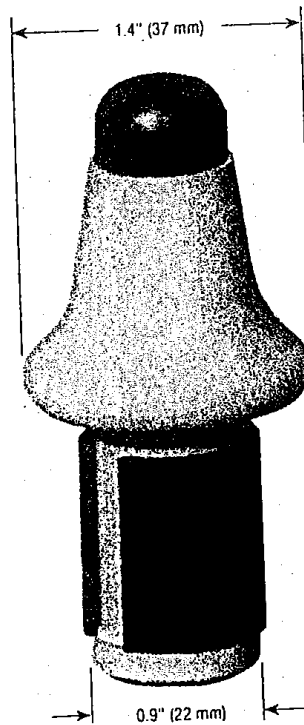

K1LS-2244-28

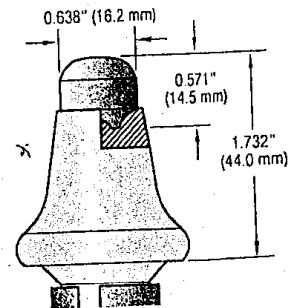

Truck

The Cheboygan County Road Commission is an Equal Opportunity Employer. All programs, activities and services are provided equally without regard to race, color, religion, sex, national origin or handicap.